

Installation manual

Montageanleitung • Notice de montage • Manual de montaje • Istruzioni per il montaggio

Grill stove with table LAGrillahi

Grillofen mit Rauchabzug und Tisch • Grill incluant le conduit d'extraction et la table • Grill con extractor de humo en campana y mesa • Griglia con cappa e tavolo

Diameter max 129 cm / Grill stove height max 111 cm



The producer shall have the right to make technical changes to the product • Technische Änderungen vorbehalten • Le producteur réserve le droit d'effectuer des modifications techniques au produit • Il produttore **si riserva** il diritto di apportare modifiche tecniche al prodotto • Reservado el derecho a modificaciones técnicas • Produsent forbeholder seg retten til å endre tekniske egenskaper ved produktet • Alle rechten en technische wijzigingen voorbehouden

Pos	SPECIFICATION – STÜCKLISTE – NOMENCLATURE – ESPECIFICACIÓN – SPECIFICHE – SPETSIFIKATSIOON	Pcs	Profile (mm)	Lenth, Height (mm)
1	Barbecue – Grill – Grill	1	Ø 574	1110
2	Ash tray – Aschekasten – Bac à cendres – Cenicero – Cassetto raccolta ceneri – Tuhasahtel	1	220x280	60
3	Smoke extraction hood – Rauchabzugshaube – Hotte d'extraction – Campana de extracción de humos – Cappa aspirazione fumi – Suitsu väljatõbmekubu	1	Ø 880	630
4	Chimney – Schornstein – Conduit bas de la cheminée – Chimenea – Camino – Korsten	1	Ø 290	1000
5	Chimney – Schornstein – Conduit haut de la cheminée – Chimenea – Camino – Korsten	1	Ø 295 / 455	1000
6	Chimney roof cap – Schornsteinhaube – Chapeau de la cheminée – Caballete Chimenea – Comignolo sul tetto – Korstna „müts“	1	Ø 500	500
7	Wooden table plate – Holztischplatte –Plateau de table en bois – Tabla de madera de la mesa – Piano di lavoro in legno – Puidust lauaplaat	3	340x40	625/1335
8	Carrier for table plate – Träger für Tischplatte – Support de table – Suporte para tabla de mesa – Supporto per tavolo – Lauaplaadi kandur	3+3	85x30	340
9	Barbecue rest – Grillrost – Grille de barbecue – Parrilla – Vassoio raccogli grassi – Grillrest	1	Ø 420	
10	Carrier for barbecue rest – Grillrosthälter – Support de la grille de barbecue – Parrilla - Supporto per vassoio raccogli grassi – Grillresti kandur	1	Ø 435	640
11	Fixator for barbecue rest carrier – Befestigung für Grillrosthälter – Fixateur pour le support de la grille de barbecue – Accesorio fijador de parrilla – Perno di fissaggio per vassio raccogli grassi – Grillresti kandja kõrguse fiksaator	1	105x105	
12	Screw for wooden table – Schraube für Holztisch – Vis pour la table en bois – Tornillo para la mesa de madera – Vite per tavolo in legno – Kruvi puidust lauale	12	Ø 4.5	30
13	Chimney fixing chain – Befestigungskette für Schornstein – Chaîne pour fixer la cheminée – adena de fijación de la chimenea – Catena di fissaggio della cappa – Korstna kinnituskett	4		1930
14	Puller – Abzieher – Extracteur – Extractor – Tenditore – Tõmmits	4		95
15	Hook – Haken – Crochet – Gancho – Gancio – Konks	4		50
16	S-hook – S-Haken – S-crochet – Gancho S – Gancio a S – S-konks	4		25

Pos. 1

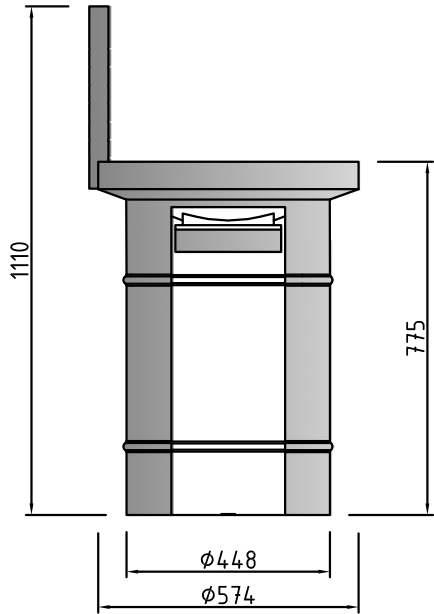

Pos. 1 + 2 + 7 + 8 + 9 + 10 + 11

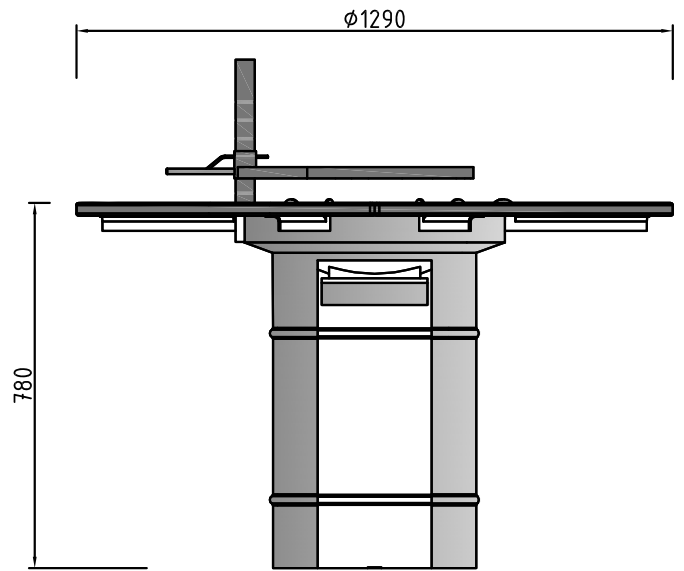

Pos. 3

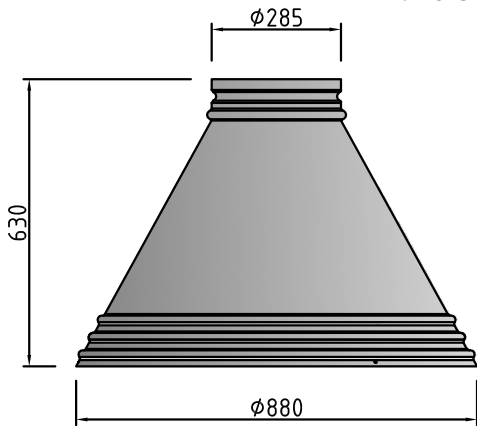

Pos. 4

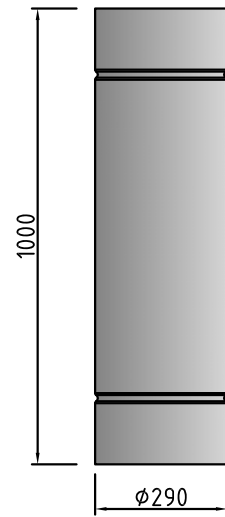

Pos. 5

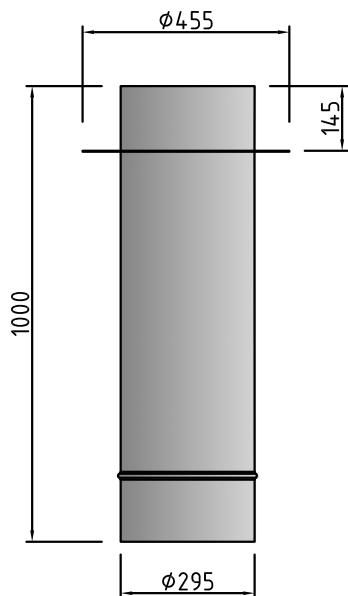

Pos. 6

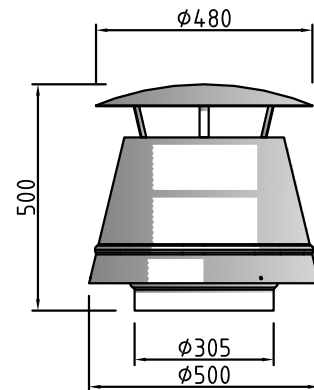

Grill stove with table LAGrillahi

